

Parts List		
NAME	DESCRIPTION	QTY
A	9 x 10 x 3/8 PLATE	1
B	2 x 10 x 3/8 PLATE	1
C	6 x 9-7/8 x 1/4 PLATE	2
D	6 x 7 x 1/4 PLATE	1
E	6.06 x 7 x 1/4 PLATE	1
F	5 x 7 x 1/4 PLATE	1
G	2" STD. PIPE x 3	1
H	2.06 DIA. x 1/8 PLATE	1
I	1 x 6 x 1/4 PLATE	1
K	1-1/2 x 6 x 1/4 PLATE	1

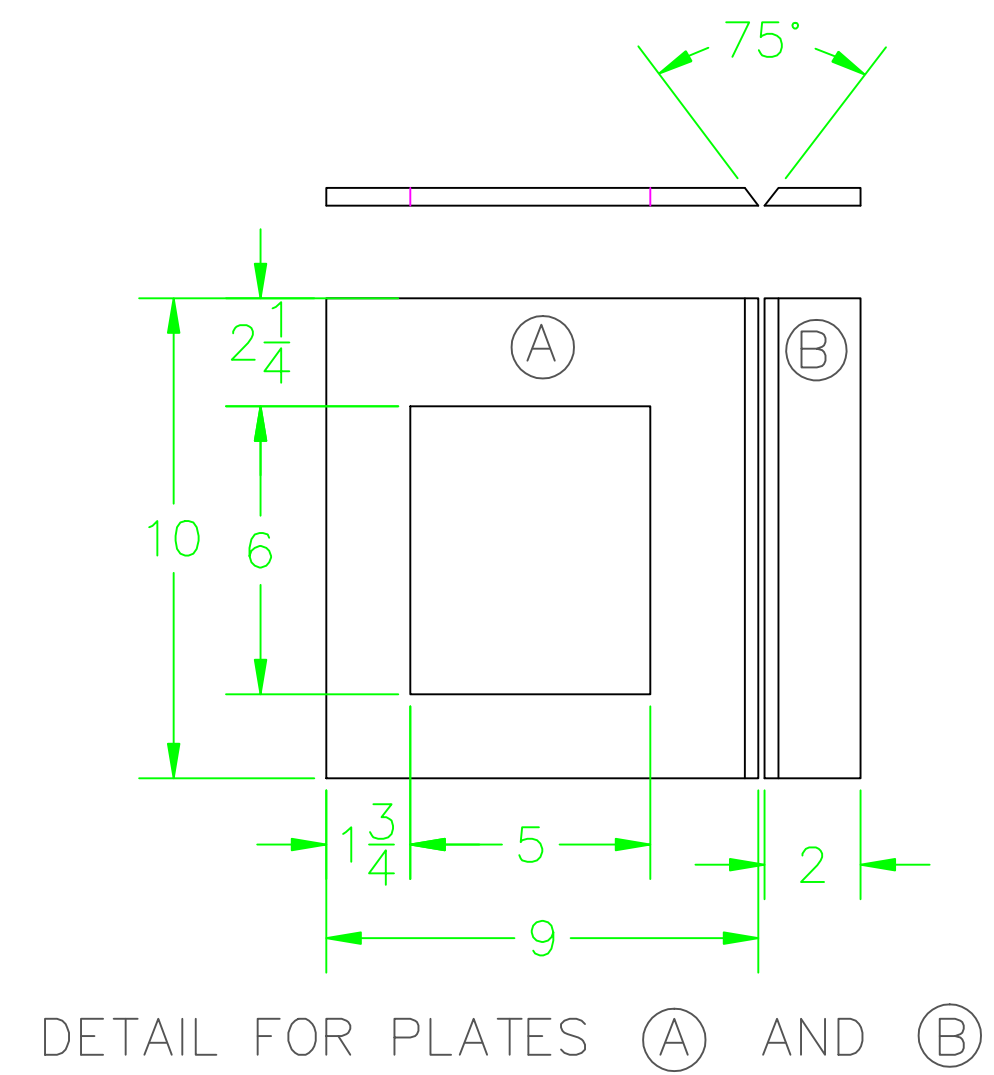

ALL DIMENSIONS IN INCHES

G: \backgrounds\pics\skill_logo.jpg

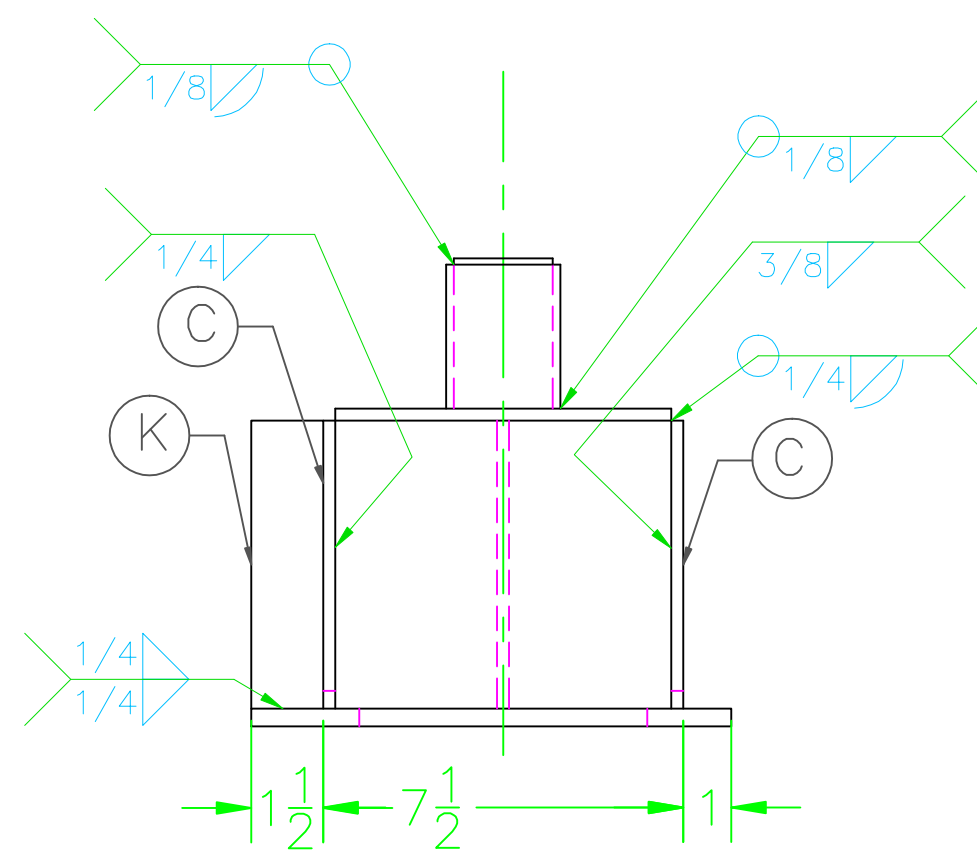
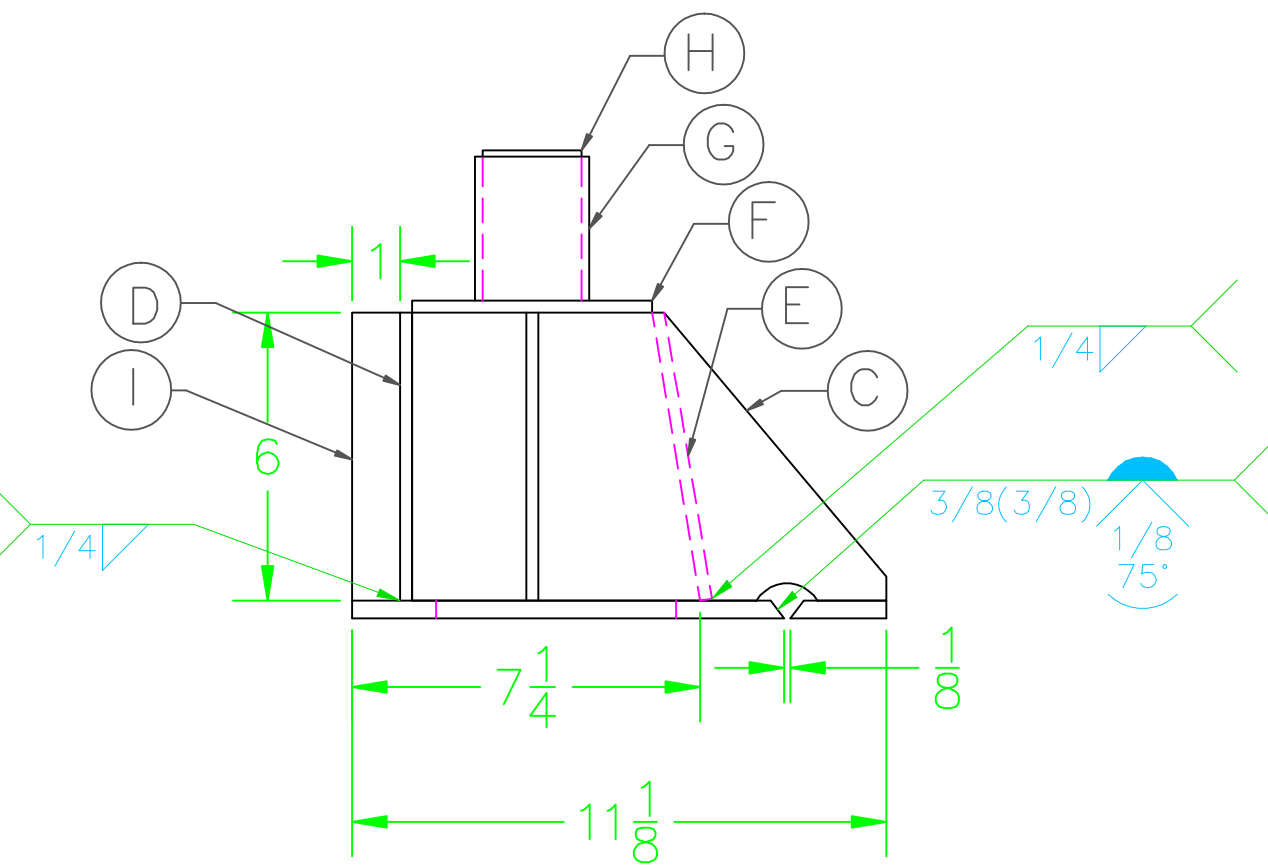
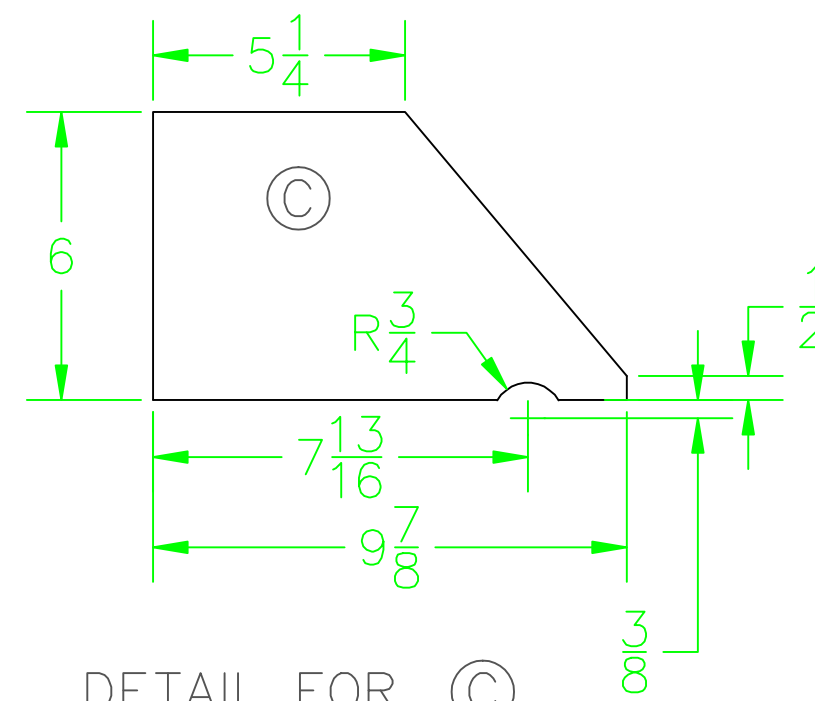
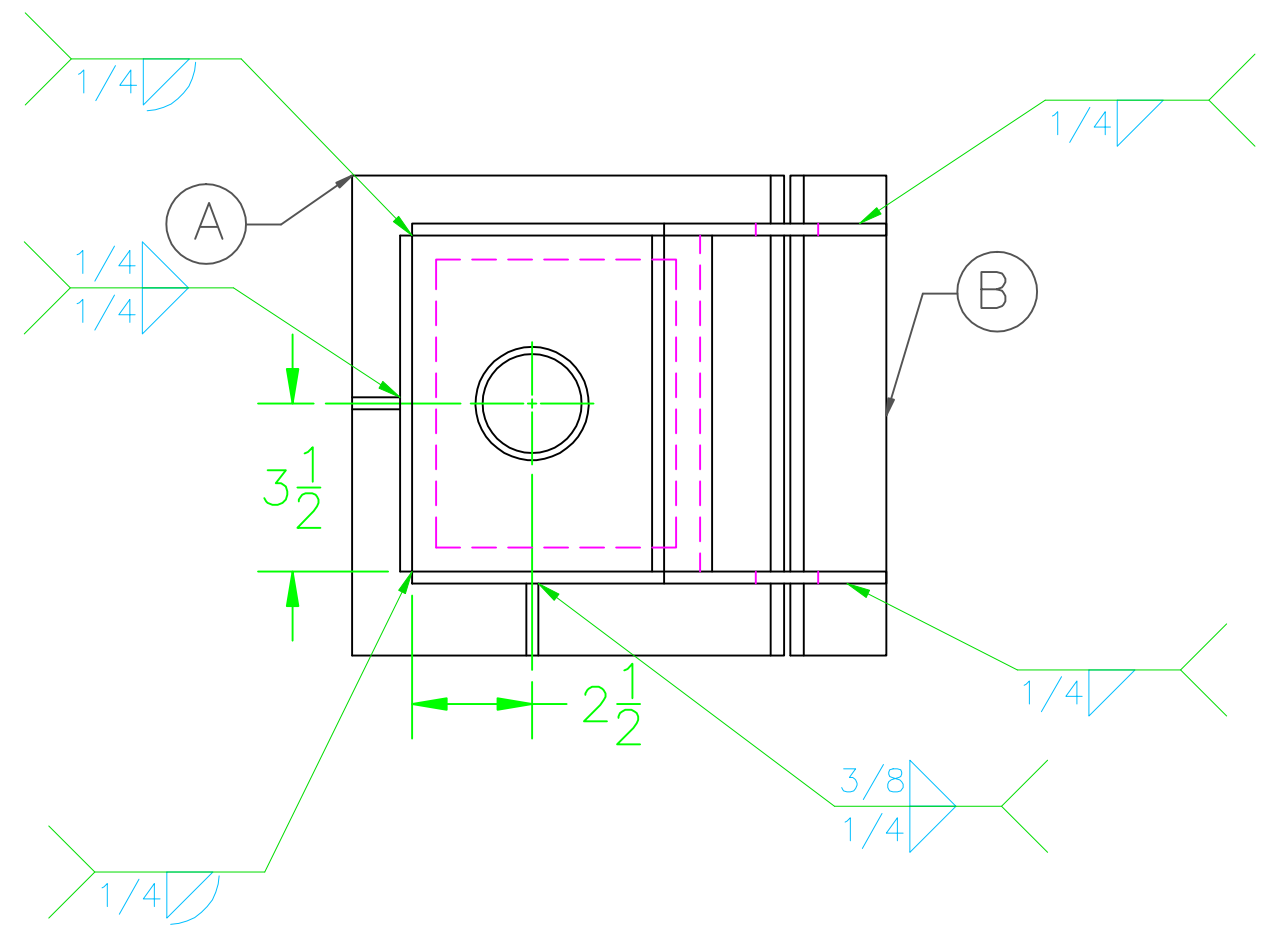

PART NAME: SKILLS CANADA – SECONDARY

DRAWN BY: ALAN NIXON

DATE: 04/12/08

SCALE: 1:4